

MTH

- Storing tank with stainless steel supporting vertical legs.
- Discharge pipe with 90° elbow.

TECHNICAL FEATURES

Stainless steel cold-rolled AISI 304 tank (AISI 316 upon request), 2b finish. Cold-forged bottom covers with optimised shape, minimum thickness: 2 mm. Robotized TIG welding process. Pickled and passivated seams.

AISI 304 stainless steel **supporting legs**. Height can be modified upon request.

Max hydraulic test pressure:
2.0 bar (200 Kpa).

Max working pressure:
0.5 bar (50 Kpa).

ACCESSORIES UPON REQUEST

- Different types of rapid fittings or nipples.
- Stirrers, washing systems, etc.
- Level gauges.
- Insulation and heating plates.
- Dimensional changes and customised equipment to meet all needs.

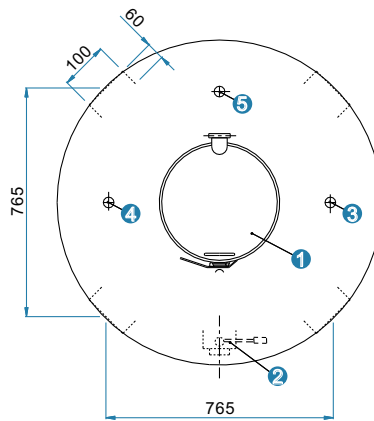
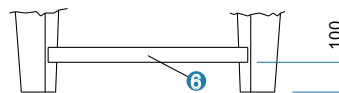
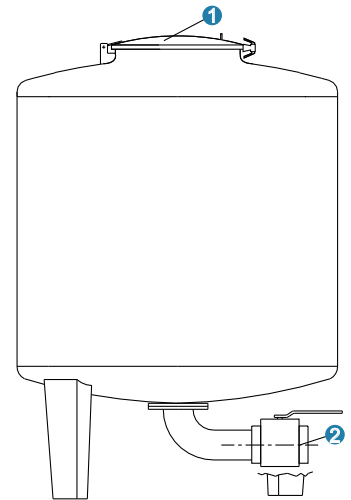
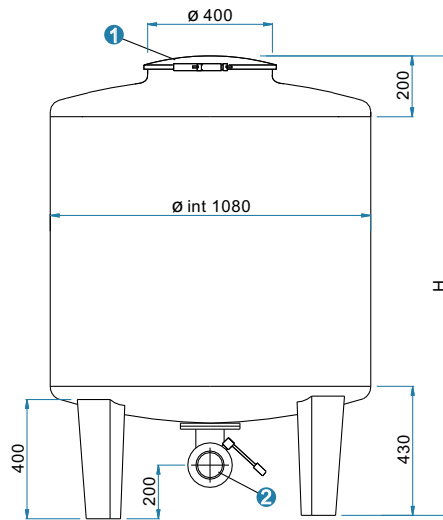

EQUIPMENT

- 400 mm. diameter manhole
 - Lid with clamp closure (standard)
 - Lid with six swing bolts (upon request)
- Ball or butterfly outlet, max diam. DN 80 (3")
- 1" diam. threaded connection for safety valve:
 - Pressure relief valve (max press. 0.5 bar)
 - Double action (+ 0.5 bar / - 0.02 bar)
- 2" threaded connection
- Additional connection, max 3" diam. (upon request)
- Bar for handling with lifting truck (upon request)

MODEL	capacity liters	tare weight Kg	base thickness mm	height H mm
MTH 500	530	90	1.8	1030
MTH 750	735	105	1.8	1250
MTH 1000	997	120	1.8	1530
MTH 1100	1080	125	1.8	1630
MTH 1250	1310	140	2.0	1880
MTH 1500	1540	155	2.0	2130
MTH 2000	2000	200	2.0	2630